



# Electric Power Steering

## ASSEMBLY INSTRUCTIONS

### Table of Contents

Motor installation .....	1
Control Module mounting .....	6
Wiring .....	8
Troubleshooting .....	10

✂ 4mm hex key, ½", 10mm wrenches, marker, hack saw, measuring tape

🛠 Electric steering components, Hot Rod steering shaft components.

👉 The power steering unit may need to be rotated in order to clear the engine or oil pan that is being used. The bearing mount has holes to fit the Coyote and 302 Ford engines with a stock style oil pan. If a different pan or engine is used, it is better to install the engine without the power steering unit installed or only installed with one bolt and the motor pointed down to make sure there is no interference.

👉 Pictures may show an older style electric steering unit and u-joints.

### Motor installation

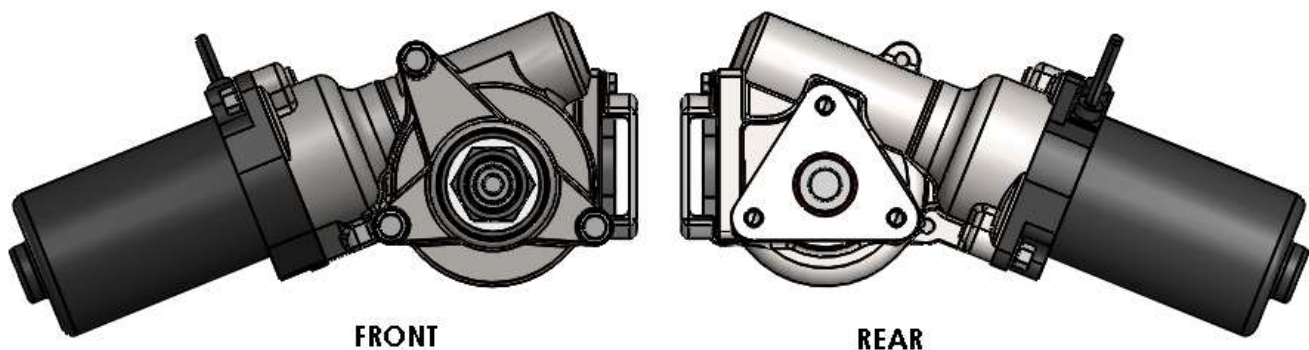

Attach a joint to the front of the electric steering unit.



Mount the electric steer unit on the frame mount below the engine mount. It is mounted on the front face of this bracket with the M8 screws provided.

Attach an FFR #33977 splined to  $\frac{3}{4}$ " DD u-joint to the front of the motor so the end of the motor shaft is flush to the inside of the joint.



Attach the rack joint onto the steering rack so the screw is on the flat side and the end of the rack is flush to the inside of the joint.

Measure the length of shaft needed to connect the to joints measuring to the inside of the joints.  
Cut the lower 33440 steering shaft to fit.



Insert the  $\frac{3}{4}$ " DD shaft into the steering rack and motor joints.

Tighten the locking screws and nuts for the front shaft u-joints using a 4mm hex key and ½” wrench.



Hold the middle shaft up to the joint that is mounted on the firewall and mark where the shaft needs to be cut so that the end is flush with the inside of the joint.



Remove the shaft and cut the end of the shaft with a hack saw or similar and grind the end of the shaft so that it will slide into the joint a little easier.



Insert the shaft into the joint on the firewall.



Tighten all of the set screws, jam nuts and flange bearing fasteners. Don't forget to Loctite the small set screw on the firewall joint.

## Control Module mounting

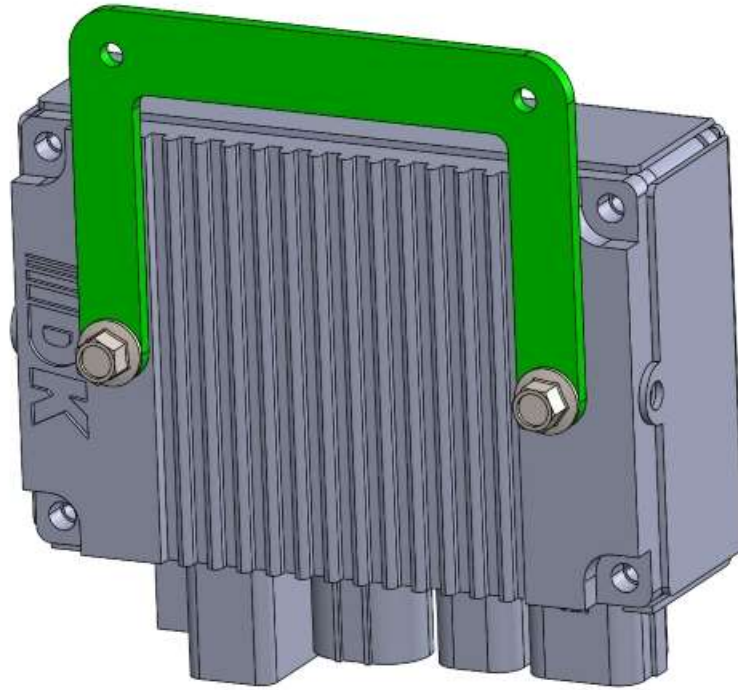

Attach the mounting bracket to the motor controller using the M6 screws.



Attach the controller harness to the motor.



Attach the power wire harness to the motor.



Run the harnesses up behind the dash area.

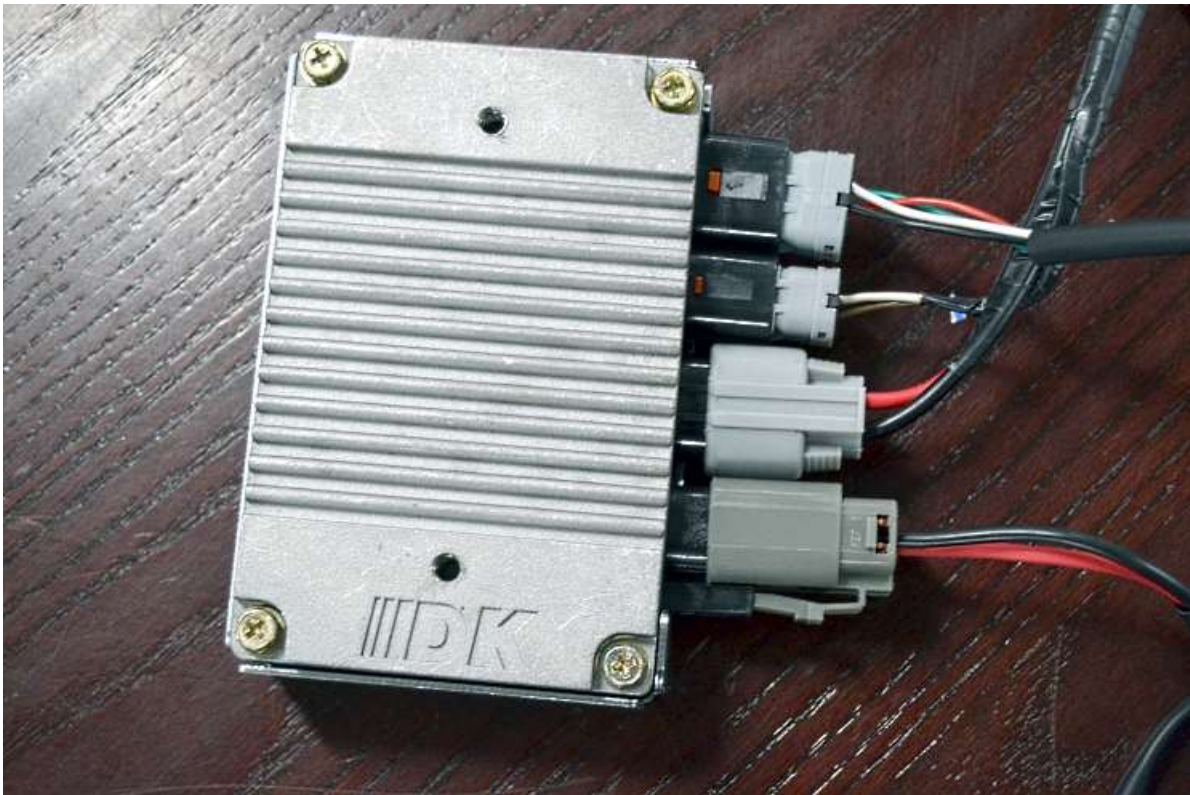

Attach the harnesses to the appropriate plug on the controller.

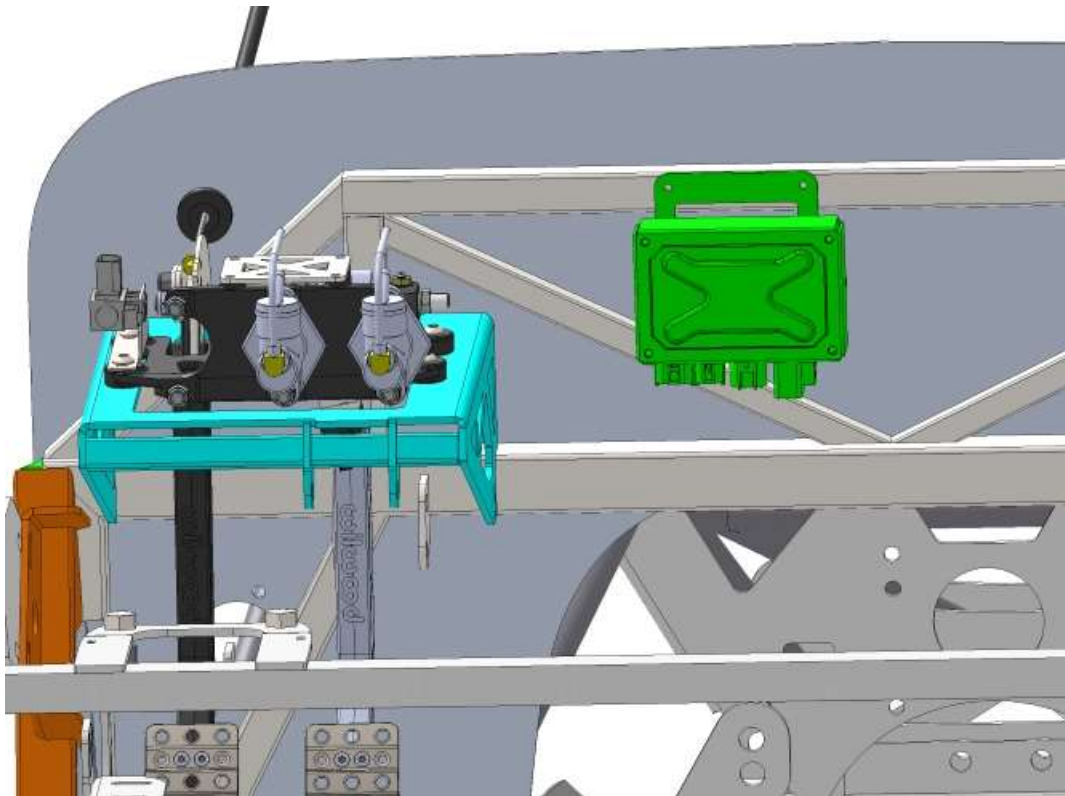

Attach the controller behind the dash area using the self-tapping #10 screws so that the harnesses will reach.

## Wiring

👉 Return to this section and do the wiring after the chassis harness is installed.





Included harnesses

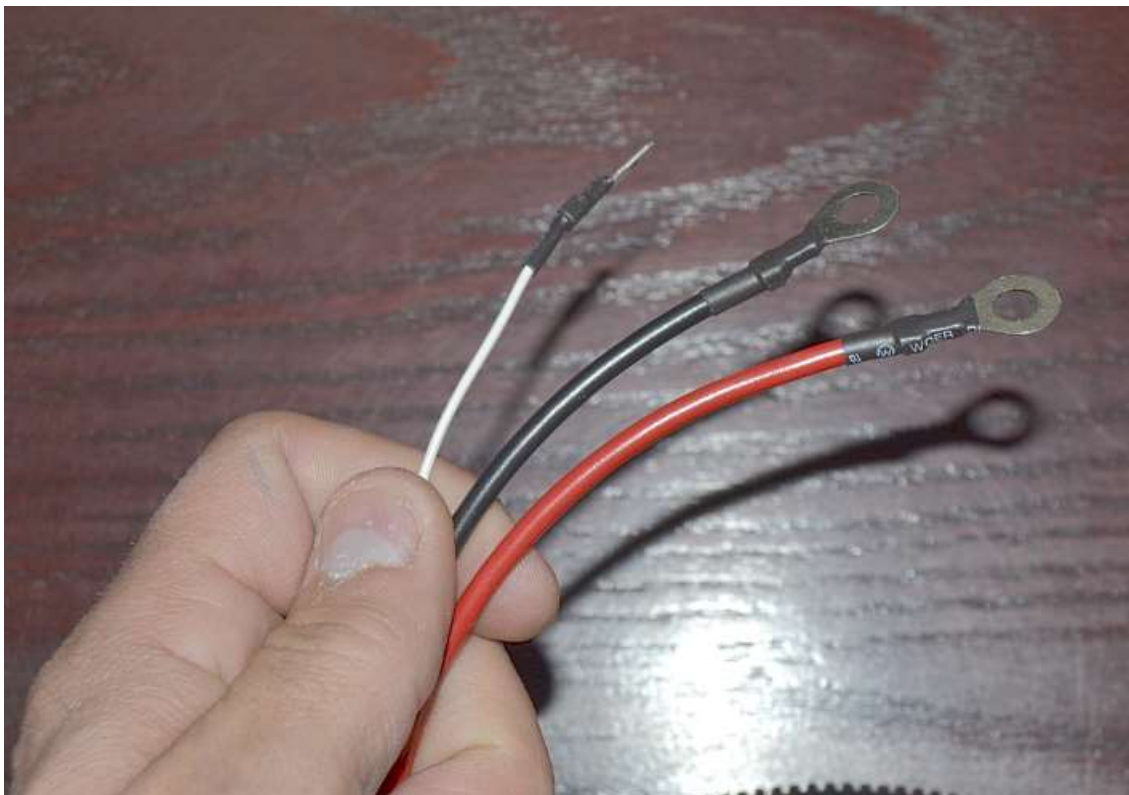

Wire the large red wire to constant +12 volts. This has a 40A inline fuse and can get connected directly to the battery cable such as on the starter battery lug.

The heavy black wire should get grounded.

Connect the white wire to a switched +12 volts. This can be done by either running a wire directly to the key or, if running an EFI car or Carb without electric choke, the tan “electric choke” wire can be used. Remove it from the Sending unit plug and connect the wires together. This only turns the system on and uses 0.1A. A 5A fuse is good for this.

✋ If an existing circuit is used such as the “electric choke” for something other than the original purpose, make sure to note the new function on the fuse panel and also make sure the correct fuse size is used.

## Troubleshooting

If there is a malfunction with the system, it will flash a code to identify the problem. Each fault code is shown by a series of flashes with the inline light.

Every fault code is a double digit shown by a series of long and short flashes of light. Each long flash represents a tens digit and is 2 seconds long and each short flash represents a single digit and is 1 second long. There will be a 3 seconds space between the long flashes and the short flashes.

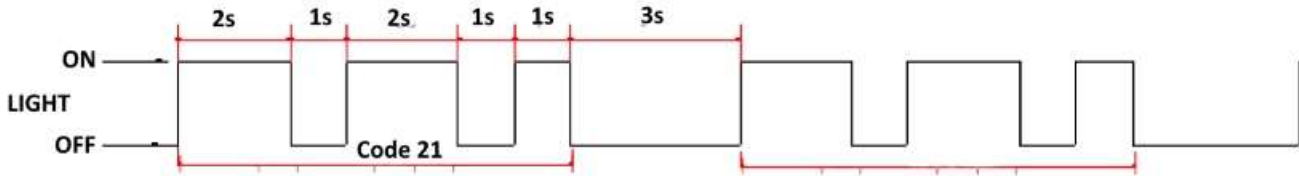

For example: Long flash\long flash \space\short flash represents the code number 21.

### Light Codes

21	Main torque sensor disconnection	1. Check sensor wiring harness 2. Replace ECU
22	Main torque sensor output error (voltage is too high or low)	
23	Vice torque sensor disconnected	
24	Vice torque sensor output error (voltage is too high or low)	
25	Main and vice torque difference is too large	
26	Main torque sensor inner fault	Replace ECU
35	Current sensor zero offset is too large	
32	Motor disconnected	Re-insert wire of the motor
33	Current of ECU is over the limit	Replace ECU
34	One side of motor has no assistance	
36	Motor voltage abnormal	Check motor wire, check motor plug

If you encounter a specific issue with the system check the chart below to see if you can find your issue and repair instructions.

Failure	Reason	Troubleshooting
---------	--------	-----------------

Steering without assistance	<ol style="list-style-type: none"> <li>1. Wiring harness connectors have a bad contact</li> <li>2. The fuse blew</li> <li>3. Relay damage</li> <li>4. Controller, motor or sensor is damaged</li> </ol>	<ol style="list-style-type: none"> <li>1. Check whether wiring harness connectors are fully inserted</li> <li>2. Replace the fuse (40A)</li> <li>3. Replace the relay</li> <li>4. Replace damaged item</li> </ol>
Power is not the same for left and right	<ol style="list-style-type: none"> <li>1. The output voltage has deviation</li> <li>2. Controller, motor or sensor is damaged</li> </ol>	<ol style="list-style-type: none"> <li>1. Disconnect motor connectors, adjust the sensor data to keep the voltage in <math>2.5V \pm 0.1V</math></li> <li>2. Replace damaged item</li> </ol>
When system is on, the steering wheel swings on both sides	<ol style="list-style-type: none"> <li>1. Motor is mounted backwards</li> <li>2. Controller or sensor is damaged</li> </ol>	<ol style="list-style-type: none"> <li>1. Swap the position of the red and black power wires at the motor</li> <li>2. Replace damaged item</li> </ol>
Steering becomes heavy	<ol style="list-style-type: none"> <li>1. Battery power loss</li> <li>2. Motor damage (power reduction)</li> <li>3. Low air pressure in front tires</li> </ol>	<ol style="list-style-type: none"> <li>1. Charge battery</li> <li>2. Replace damaged item</li> <li>3. Inflate tires</li> </ol>
System has noise	<ol style="list-style-type: none"> <li>1. Motor damage</li> <li>2. Steering u-joint to <math>\frac{3}{4}</math>"DD fitment is loose.</li> </ol>	<ol style="list-style-type: none"> <li>1. Replace damaged motor</li> <li>2. Tighten the u-joint screws.</li> </ol>